

VELAN MONOVALVE FLOAT BIMETALLIC STEAM TRAPS

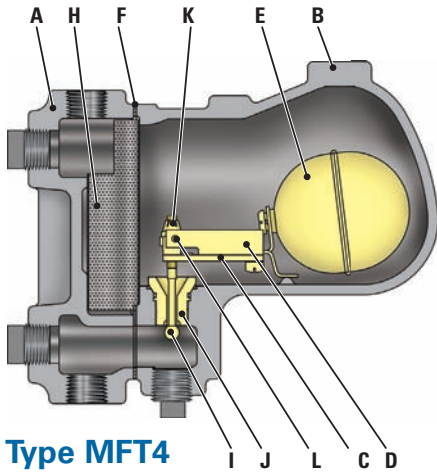

Type MFT4

STANDARD MATERIALS

PART		MATERIALS
A	Body	Cast iron Gr.250
B	Cover	Same as body material
C	Bimetal element	Truflex GB-14
D	Bimetal holder	Stainless steel
E	Float	Stainless steel
F	Cover gasket	Stainless steel with non-asbestos filler
G	Cover screw	High tensile steel Gr. S
H	Strainer	Stainless steel
I	Stem and ball	Stainless steel, ball 58Rc
J	Seat	SS hardfaced with Stellite 6
K	Self lock adjusting nut	Stainless steel
L	Pivot plug	Stainless steel

NOTE: Part 'G' is not shown for clarity

APPLICATIONS

Where positive drainage is essential and condensate back-up cannot be tolerated.

- Unit heaters,
- Laundry presses,
- Calorifiers,
- Ironers,
- Calenders,
- Drying cylinders and other applications where condensate has to be discharged at near steam temperature.

CONNECTIONS

- Screwed

ENGINEERING DATA

PRESSURE RANGE ⁽¹⁾ psi/bar	PMO psi/bar	MATERIAL	MAX TEMP °F/°C	ORIFICE in/mm	MAX CAPACITY lb/hr/kg/hr
0-15 0-1	15 1	CAST IRON Gr.250	428 220	3/4 19	17,500 7,955
15-50 1-3.5	50 3.5			1/2 12.7	12,000 5,455
50-125 3.5-8.5	125 8.5			3/8 9.5	8,000 3,636
125-200 8.5-14	200 14			5/16 8	5,800 2,636

PMA = Maximum allowable pressure: 260psi@100°F (18bar.g@38°C)

TMA = Maximum allowable temperature: 428°F (220°C)

Maximum cold hydrostatic test pressure: 400psi.g (27.5bar)

TMO = Maximum operating temperature = TMA

PMO = Maximum operating pressure: (See Table)

(1) Pressure range indicated in the above table is the preferred operating range, however the trap is functional from 0psi to its maximum operating pressure.

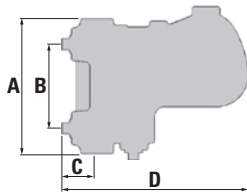

DIMENSIONS & WEIGHTS

SIZE in/mm	A (1) FACE TO FACE	B(2) CENTER TO CENTER	C(3) CENTER TO FACE	D LENGTH	WEIGHT lb/kg
2 50	11 279	6 1/2 165	2 1/4 57	14 1/2 368	51 23

(1) vertical connection (2) horizontal connection (3) Center of vertical outlet to face of horizontal outlet

CONDENSATE CAPACITY

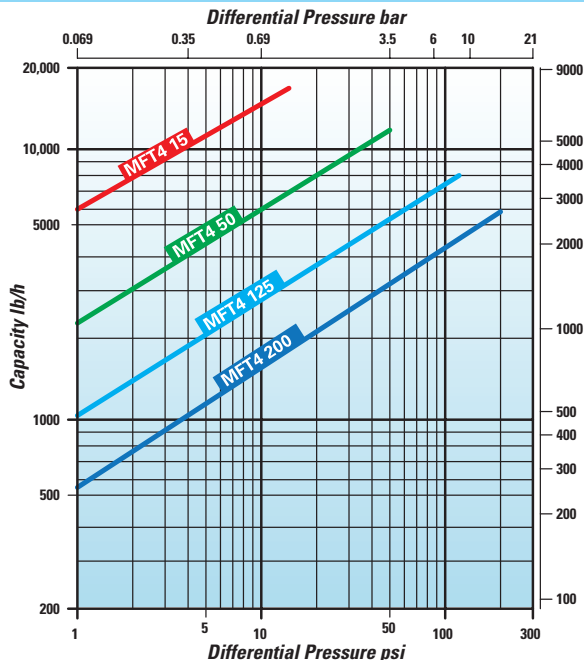

Maximum cold water capacity x 3.5

The performance graph indicates the continuous discharge capacities of condensate per hour at various pressure differentials across the trap.

PRESSURE / TEMPERATURE LIMITS

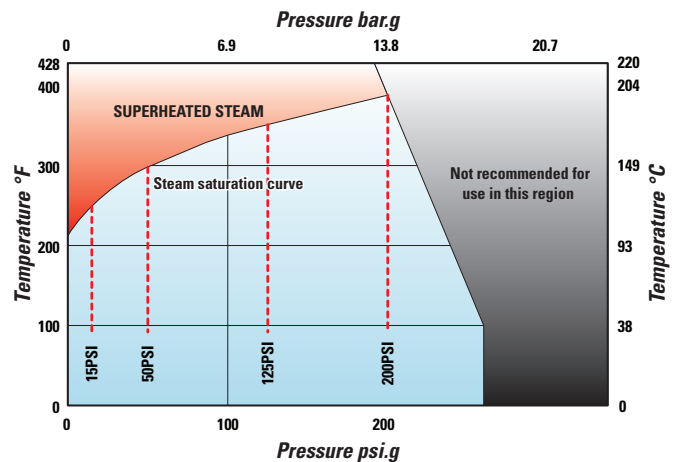

----- Pressure limit for trap type